



## CALL FOR TENDER ACTED [TURKIYE] Instructions to Bidders

Date: 27/07/2023  
Tender N°: T/17MULTI-MULTI-HAT-3ZERO-01-08-2023-1

Through this tender ACTED is requesting a company to provide detailed written offers for the supply and distribution services of the following products:

### **LOT 1: PRODUCT SPECIFICATIONS:**

- |                           |  |
|---------------------------|--|
| 1. Description:           | <b>Wooden houses (Electricity and insulation included)</b> |
| 2. Delivery address:      | Hatay/Antakya  |
| 3. Quantity/unit:         | To be determined. (Daha sonra bildirilecek)                |
| 4. Modality of delivery:  | DDP on Acted distribution sites.                           |
| 5. Market share estimate: | 90,000.00 USD  |

A detailed list of requested products is provided in the attached Offer Form.

### **RESPONSIBILITIES OF THE SUPPLIER:**

For an offer to be accepted by Acted it will need to contain the following documents, signed by the bidder.

1	The present <b>Instructions to Bidders (PRO-05)</b> signed & stamped by the Bidder
2	An original <b>Offer Form (PRO-06)</b> for each sub lots dated, filled, signed & stamped by the Bidder ( <i>detailed as per the requested currency</i> )
4	An Original <b>Technical offer</b> . dated, filled, signed & stamped by the Bidder ( <i>detailed as per the requested currency</i> )
5	<b>Catalogues AND technical drawing</b> of each of the wooden house proposed, made by your company based on Acted requirements.
3	The <b>Bidder's official registration documents</b>
4	The <b>book of specification</b> signed and stamped.

**It is important to note that all documents must be filled, dated, signed & stamped by the Bidders in order to be considered as eligible. ACTED only accepts bids that have been filled in in either English or Turkish.**

### **GENERAL CONDITIONS:**

- Information session will be organised as follow, you are invited to join, Acted will present the rules of the tender, the quality required and answer to your questions. :
  - Wooden house: Connect to the following link on the 09/08/2023 at 13:00 Gaziantep time  
[Click here to join the meeting](#)
- The **closing date** of this tender is **14 / 08 / 2023** at 12:00 Gaziantep/Turkiye time.  
The submission of the proposal is electronic; all Proposals shall be submitted as a soft copy via email with due consideration to the following:  
- Email Address:  
To: Sofiane HAMDİ sofiane.hamdi@acted.org





CC : Vincent MARCHETTI< vincent.marchetti@acted.org>; Rizkullah TOLUN  
rizkullah.tolun@acted.org

The size of one Email (including all attachments) shall not exceed 10 MB. - The reference number of the Tender T (T/17MULTI-MULTI-HAT-3ZERO-01-08-2023-1) shall be the Subject of the email.

- Late offers may not be considered.
- To ensure that funds are used exclusively for humanitarian purposes and in accordance with donors' compliance requirements, all offers are subject to the condition that contractors do not appear on **anti-terrorism lists**, in line with ACTED's anti-terrorism policy. To this end, ACTED reserves the right to carry out anti-terrorism checks on any contractor, its board members, staff, volunteers, consultants, financial service providers and sub-contractors.
- Collusive practices are prohibited and will lead to offers rejection.
- **ACTED adopts a zero tolerance approach towards corruption and is committed to respecting the highest standards in terms of efficiency, responsibility and transparency in its activities. In particular, ACTED has adopted a participatory approach to promote and ensure transparency within the organization and set up a Transparency unit (supervised by the Director of Audit & Transparency) that can be reached through a dedicated phone number and e-mail address. As such, if you witness or suspect any unlawful, improper or unethical act or business practice (such as soliciting, accepting or attempting to provide or accept any kickback) during the tendering process, please contact the following phone number +33 6 07 22 46 28 and/or send an e-mail to [transparency@acted.org](mailto:transparency@acted.org).**

#### SPECIAL CONDITIONS:

- Bids award criteria will be assessed through a:

##### **Pass/fail method**

The cheapest supplier that passes the technical evaluation will be awarded a Framework agreement. **Samples of the supplied materials** might be request for technical evaluation purposes, in case they are it will be at the cost of supplier. Also Acted reserves the right to **visit supplier premises**.

- Acted reserves the right to contract one or more suppliers.
- In case of providing multiple options for one item, ACTED reserves the right to either select any one of the options or not consider the line item at all.
- ACTED reserves the right to engage on **Post-Tendering Price negotiation** with the bidders in form of submission of Counteroffer or direct price negotiation.
- Sending their offers to the present call for tender, Bidders acknowledge their agreement with these terms & conditions.
- ACTED will accept one final offer from each bidder that participates in the Tender. If a bidder wishes to submit an updated Proposal, after submitting their first offer but before the closing date, this should be clearly marked in the Email and Financial Offer.
- Each Bid shall include a unique company name, representative and signature, phone number, and email address. Any similarities between Proposals could result in the bid being rejected.
- Company Stamps should be unique and should include the company name. All information contained in the stamp should be unique to the company submitting the offer. Bidders who use multi stamps will not be considered.
- Electronic stamp and signatures are not accepted but the tender submission is electronic.
- The offer will not be considered eligible if white ink is used, or price corrections are done by hand.
- This tender will lead to the signature of a framework agreement valid until 31/12/2023 and could be extended.





**ACTED**

LOGISTICS  
PRO-05  
Version 01/2022

Company Name:

\_\_\_\_\_

Authorized Representative Name:

\_\_\_\_\_

Signature:

\_\_\_\_\_

Stamp:

\_\_\_\_\_



**LOT 1: WOODEN HOUSE OFFER FORM ACTED *TURKIYE***

RFQ N° (filled in by ACTED): 17MULTI-MULTI-HAT-3ZERO-01-08-2023-1

Date (filled in by Bidders):

**To be Filled by Bidder (COMPULSORY)**

<b>Company's Name</b> (as per registration documents)	
<b>Company Authorized Representative's Name</b> (as per registration documents or duly signed Power of Attorney)	
<b>Company Registration Number</b>	
<b>Registration body</b>	
<b>Company's mailing address</b> Shop/Office/Building No Street name City Governorate/province/district Country	
<b>Commercial representative for the bid</b> (if different from authorized representative)	
<b>Phone contact number</b> Landline Mobile No	
<b>Email address</b>	

**IMPORTANT NOTE: IF THE SUPPLIER DOES NOT OFFER MODELS MATCHING ACTED SPECIFICATION, THE BIDDER IS STILL ALLOWED TO PROPOSE AN OFFER BASED ON ITS CATALOG, TO DO SO, PLEASE PROVIDE YOUR OWN QUOTATION AND DETAILED SPECIFICATION AND DRAWING OF EACH MODEL PROPOSED.<sup>1</sup>**

<sup>1</sup> By doing so, the contractor understands that Acted selection will always favor houses matching the requested specification for the tender.



**THE SUPPLIER CAN GIVE A PRICE FOR AS MANY SUB LOTS HE WISHES TO APPLY ON.**

Index	Description -	Specification	UNIT - BIRIM	Unit Price in USD inclusive of value added tax (VAT)	SUPPLIER'S COMMENTS
<b>Sub lot 1 Wooden house 4x3</b>					
1.1	Wooden house 4x3 Meter	Please refer to book of specification, price includes manufacture and site installation	piece		
1.2	Wooden house 4x3 delivery cost	The price should be given for the delivery cost and offloading anywhere in Hatay, price should be given in USD/HOUSE	Per unit delivered		
<b>Sub lot 2 Wooden house 4x5</b>					
2.1	Wooden house 4x5 Meter	Please refer to book of specification, price includes manufacture and site installation	piece		
2.2	Wooden house 4x5 delivery cost	The price should be given for the delivery cost and offloading anywhere in Hatay, price should be given in USD/HOUSE	Pce per unit delivered		
<b>Sub lot 3 Wooden house 4x6</b>					
3.1	Wooden house 4x6 Meter	Please refer to book of specification, price includes manufacture and site installation	piece		
3.2	Wooden house 4x6 delivery cost	The price should be given for the delivery cost and offloading anywhere in Hatay, price should be given in USD/HOUSE	Pce per unit delivered		
<b>Sub lot 4 Wooden house 4x8</b>					
4.1	Wooden house 4x8 Meter	Please refer to book of specification, price includes manufacture and site installation	piece		
4.2	Wooden house 4x8 delivery cost	The price should be given for the delivery cost and offloading anywhere in Hatay, price should be given in USD/HOUSE	Pce per unit delivered		
<b>Sub lot 5 Insulation (OPTIONAL)</b>					
5.1	Wood Wool insulation	80mm thickness, adapted to the walls and roof design of the houses, thermic resistance of 2.2 R [(m <sup>2</sup> *K)/W]. all installation (sandwiched) is included in the price	Price per m2(square meter)		
5.2	Glass wool insulation	80mm thickness, adapted to walls and roofs design of the houses, all installation (sandwiched) is included in the price	Price per m2(square meter)		



**IMPORTANT NOTE: IF THE SUPPLIER DOES NOT OFFER MODELS MATCHING ACTED SPECIFICATION, THE BIDDER IS STILL ALLOWED TO PROPOSE AN OFFER BASED ON ITS CATALOG, TO DO SO, PLEASE PROVIDE YOUR OWN QUOTATION AND DETAILED SPECIFICATION AND DRAWING OF EACH MODEL PROPOSED.<sup>2</sup>**

**GENERAL REMARKS**

I undersigned (to be filled in by Bidders)

\_\_\_\_\_ agree to provide ACTED, a non-profit NGO, with items answering the following specifications, according to the general conditions and responsibilities that I engage myself to follow.

“By signing this document I hereby attest that I read all the offer form and understood all the conditions of this document, but also that I have studied carefully Acted technical requirement and that my price includes all its requirements.”

Name of Bidder's Authorized / İstekli Yetkilinin Adı:

Representative/ Temsilci: \_\_\_\_\_

Authorized signature and stamp/ Yetkili imza ve kaşe: \_\_\_\_\_

Date/Tarih: \_\_\_\_\_

\_\_\_\_\_ <sup>2</sup> By doing so, the contractor understands that Acted selection will always favor houses matching the requested specification for the tender.



**TECHNICAL QUESTIONNAIRE ACTED *TURKIYE***

RFQ N° (filled in by ACTED): 17MULTI-MULTI-HAT-3ZERO-01-08-2023-1

Date (filled in by Bidders):

This tender will follow a PASS/FAIL selection method, the supplier that proposes the cheapest price and that matches the below technical requirement will be awarded a contract with Acted.

Criteria	Scoring	Document requested
Are the model proposed matching Acted technical requirements for specification detailed in below book of specification?	PASS/FAIL	Catalog and Technical drawings, filling Table A
Is the production capacity of the supplier matching Acted operational constraints	PASS/FAIL	Technical offer, filling of table A
Is the supplier specialized in the manufacture of wooden houses	BONUS POINT	Registration

Please fill out the following table:

**TABLE A: Please answer the following questions about your wooden house products.**

Question	Answer
Wooden house 4x3 Meter	
What are the internal dimension of your house (In meter)	
Did you attach a catalog and a technical drawing of the house you propose, showing clearly a top view, and base, walls and roof designs.	
Can you describe the electrical installation your model inscludes?	
How many units can you produce in 10 working days ?	
Do you offer maintenance services or after-sales support?	
Do you offer a warranty on their houses? What are the terms and conditions of the warranty?	
How many years of experience do you have in the manufacturing of wooden houses	



Do you utilize specific treatments on the wood to ensure it is resistant to moisture and rainfall? please specify	
Do you apply specific treatments to the wood to guarantee its resistance against pests? please specify	
<b>Wooden house 4x5 Meter</b>	
What are the internal dimension of your house (In meter)	
Did you attach a technical drawing of the house you propose, showing clearly a top view, and base, walls and roof designs.	
Can you describe the electrical installation your model includes?	
How many units can you produce in 10 working days ?	
Do you offer maintenance services or after-sales support?	
Do you offer a warranty on their houses? What are the terms and conditions of the warranty?	
How many years of experience do you have in the manufacturing of wooden houses	
Do you utilize specific treatments on the wood to ensure it is resistant to moisture and rainfall? please specify	
Do you apply specific treatments to the wood to guarantee its resistance against pests? please specify	
<b>Wooden house 4x6 Meter</b>	
What are the internal dimension of your house (In meter)	
Did you attach a technical drawing of the house you propose, showing clearly a top view, and base, walls and roof designs.	
Can you describe the electrical installation your model includes?	
How many units can you produce in 10 working days ?	
Do you offer maintenance services or after-sales support?	
Do you offer a warranty on their houses? What are the terms and conditions of the warranty?	
How many years of experience do you have in the manufacturing of wooden houses	





Do you utilize specific treatments on the wood to ensure it is resistant to moisture and rainfall? please specify	
Do you apply specific treatments to the wood to guarantee its resistance against pests? please specify	
<b>Wooden house 4x8 Meter</b>	
What are the internal dimension of your house (In meter)	
Did you attach a technical drawing of the house you propose, showing clearly a top view, and base, walls and roof designs.	
Can you describe the electrical installation your model includes?	
How many units can you produce in 10 working days ?	
Do you offer maintenance services or after-sales support?	
Do you offer a warranty on their houses? What are the terms and conditions of the warranty?	
How many years of experience do you have in the manufacturing of wooden houses	
Do you utilize specific treatments on the wood to ensure it is resistant to moisture and rainfall? please specify	
Do you apply specific treatments to the wood to guarantee its resistance against pests? please specify	

"By signing this document I hereby attest that I read all the offer form and understood all the conditions of this document, but also that I have studied carefully the book of condition and that my price includes all its requirements:"

Name of Bidder's Authorized / İstekli Yetkilinin Adı:

Representative/ Temsilci: \_\_\_\_\_

Authorized signature and stamp/ Yetkili imza ve kaşe: \_\_\_\_\_

Date/Tarih: \_\_\_\_\_



**BOOK OF CONDITION - ACTED *TURKIYE***
**Wooden HOUSE 4x3m  
 Production Dimensions**

External Dimensions: 3740\*4740 mm

Internal Dimensions: 3000\*4000 mm

Interior Space m<sup>2</sup>: 12

It consists of 7 panels in total.

(Base, side right and left panel, front rear panel, two roof panels)

**Technical Data**

snow load: 80 kg/m<sup>2</sup>

Wind load: 105 km/hr

All sections are shown in the attached Plan.

**Base**

1-2 class Yellow Pine/Spruce Timber with Oven frame, measuring 6\*9 cm, should be used as floor wedges. On it, 1-2 class San Pine/ Spruce Oven timber frame with 27 mm thickness should be nailed with 2.5\*70 mm ring nails. The humidity of the material to be used should be below 15%. Total package thickness is 12 cm. The floor should be painted with water-based paint-varnish. The materials to be used on the base must be waterproof And on top of the pine/Spruce wood , plywood plate 18mm thickness with gray color waterproof paint.

**Exterior Walls**

Paneling made of 1-2 class Yellow Pine/Spruce Timber frame should be used. It must be made of wood with oven-timber and the humidity must be below

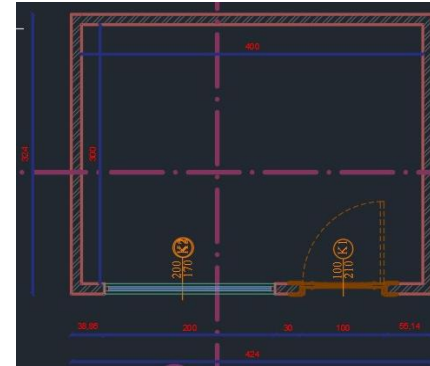

Figure: Top view

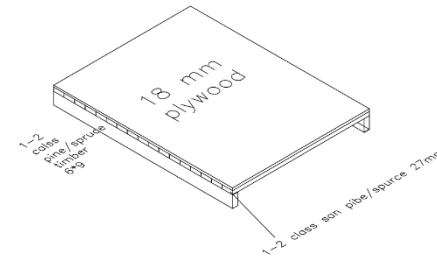
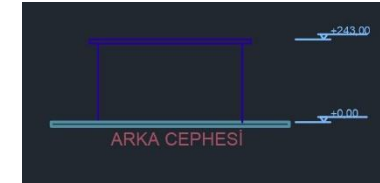
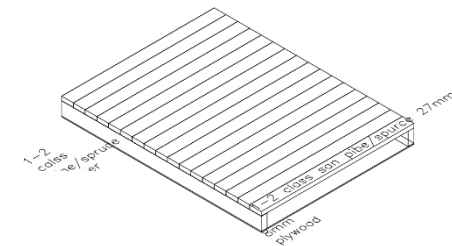

Figure : Base design



15%. The width of the panel should be 10 cm, 12 cm and 15 cm. The Main Carcass measures 4\*9 cm and the paneling should be fixed to this carcass. Water-based varnish should be applied on the paneling and waterproofing should be provided. A light single color should be used. Paneling should be nailed with 25\*55 mm ring nails.

### Interior Walls

1-2 class Yellow Pine/Spruce Timber frame should be used in 4\*9 cm Wood Carcass and the humidity rate should be below 15%. Panel width should be 10 cm, 12 cm and 15 cm. 8 mm MDF Lam, in other words painted MDF, should be nailed to the inside of the main carcass. MDF carrier should be nailed to the main frame with 4d headless nails and/or 2.5\*40 mm screws.

### Roof

the roof is ergonomically heavy, it consists of 2 (two) equal parts. 4\*9 cm 1-2 class Yellow Pine / Spruce kiln timber frame should be used. Humidity should be below 15%. Paneling made of 18 mm 1-2 class San Pine/ Spruce timber should be nailed to the carcass consisting of 4\*9 cm. Humidity rate should be below 15% as it is oven-panel.

2-3 mm membrane coating should be nailed on the paneling with 2 cm shingle nails. On top of that, Slate Shingle Coating should be nailed with 2 cm shingle nails. Membrane coating and Slate Shingle material must comply with TSE standards. Total thickness should be 12.5 cm. Waterproofing must be ensured. It should be applied between the roof and the outer walls with one's hand on the waist. Adding at high 2,43 m side ( PVC 110 mm k-style Rain Gutter – Brown) with all parts (end cap-brackets -corner joint..etc) .the downspout outlet And all the downspout outlet will connect with downspout section and the connection until ground.

### Electrical Installation

Figure a : Wall Design

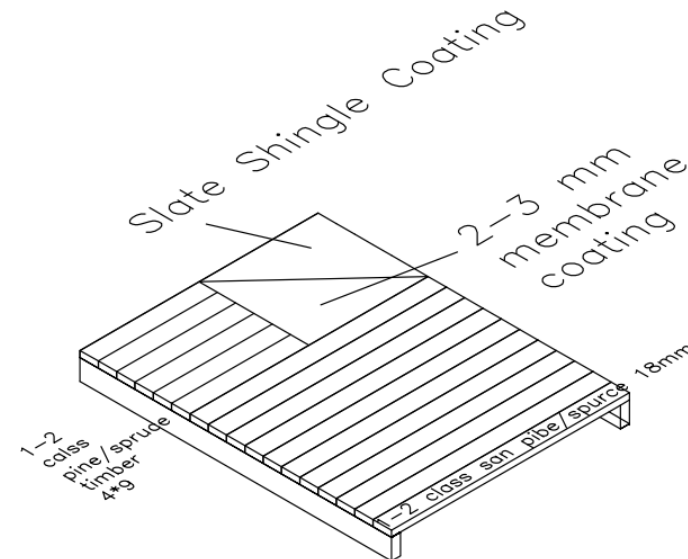

Figure b: Roof design



85mm \*85mm input junction box, one differential breaker 30mA delta, with Ampers capacity adapting to the input. Then two circuits:

- 10 amps breaker for indoor lighting + one inside socket
- 25 amp breaker for sockets should be used on the outside and one inside apparent wire to connect an AC.

Surface-mounted connections should be made. Electrical installation should be done on the right side of the door entrance and on the other side of it. The supply cable is a ttr cable with a cross section of 3\*2.5 and therefore there should be a machine etc. that will consume electricity in the shop in accordance with the load that the cable in this cross section will carry. should be used. There should be 1 socket, 1 switch, 1 lamp and button. All electrical materials must comply with TSE standards.

#### **Door**

Door dimensions: 100 \* 210 cm. The width of the frame is 10 cm and there should be a sill only on the long side and the short side on the outside. Composite / Membrane Door should be used. Exterior door lock must be used, lock, hinge and handle must comply with TSE standards. The door should open to the inside area to the right wall side. Glassless Door. White, Brown, Cream and light gray tones should be used as colors.



**Wooden HOUSE 4 x 5 type Shop consists of 1 room.**

**Production Dimensions**

External Dimensions: 4740 \* 5740 mm

Interior Dimensions: 4000\*5000 mm

Interior Space m2: 20

It consists of 7 panels in total.

(Base, side right and left panel, front rear panel, two roof panels)

**Technical Data**

snow load: 80 kg/m2

Wind load: 105 km/hr

All sections are shown in the attached Plan.

**Base**

1-2 class Yellow Pine/Spruce Timber with Oven frame, measuring 6\*9 cm, should be used as floor wedges. On it, 1-2 class San Pine/ Spruce Oven timber frame with 27 mm thickness should be nailed with 25\*70 mm ring nails. The humidity of the material to be used should be below 15%. Total package thickness is 12 cm. The floor should be painted with water-based paint-varnish. The materials to be used on the base must be waterproof And on top of the pine/Spruce wood , plywood plate 18mm thickness with gray color waterproof paint.

**Exterior Walls**

Paneling made of 1-2 class Yellow Pine/Spruce Timber frame should be used. It must be made of wood with oven-timber and the humidity must be below 15%. The width of the panel should be 10 cm, 12 cm and 15 cm. The Main Carcass measures 4\*9 cm and the paneling should be fixed to this carcass. Water-based varnish should be applied on the paneling and waterproofing

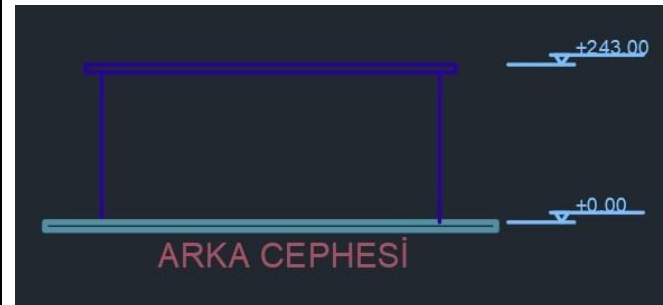
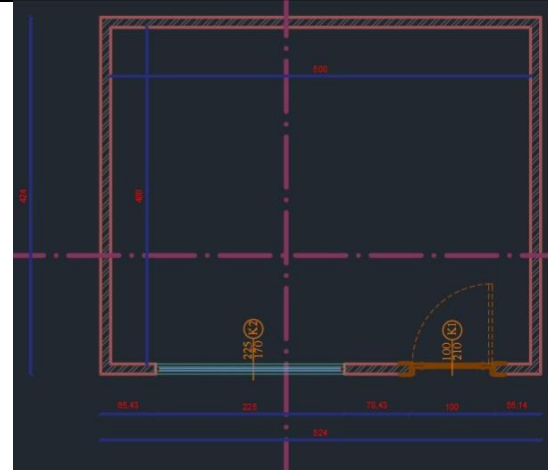

should be provided. A light single color should be used. Paneling should be nailed with 25\*55 mm ring nails.

### Interior Walls

1-2 class Yellow Pine/Spruce Timber frame should be used in 4\*9 cm Wood Carcass and the humidity rate should be below 15%. Panel width should be 10 cm, 12 cm and 15 cm. 8 mm MDF Lam, in other words painted MDF, should be nailed to the inside of the main carcass. MDF carrier should be nailed to the main frame with 4d headless nails and/or 25\*40 mm screws.

### Roof

the roof is ergonomically heavy, it consists of 2 (two) equal parts. 4\*9 cm 1-2 class Yellow Pine / Spruce kiln timber frame should be used. Humidity should be below 15%. Paneling made of 18 mm 1-2 class San Pine/ Spruce timber should be nailed to the carcass consisting of 4\*9 cm. Humidity rate should be below 15% as it is oven-panel.

2-3 mm membrane coating should be nailed on the paneling with 2 cm shingle nails. On top of that, Slate Shingle Coating should be nailed with 2 cm shingle nails. Membrane coating and Slate Shingle material must comply with TSE standards. Total thickness should be 12.5 cm. Waterproofing must be ensured. It should be applied between the roof and the outer walls with one's hand on the waist. Adding at high 2,43 m side ( PVC 110 mm k-style Rain Gutter – Brown) with all parts (end cap-brackets -corner joint..etc) .the downspout outlet And all the downspout outlet will connect with downspout section and the connection until ground.

### Electrical Installation

85mm \*85mm input junction box, one differential breaker 30mA delta, with Ampers capacity adapting to the input. Then two circuits:

- 10 amps breaker for indoor lighting + one inside socket

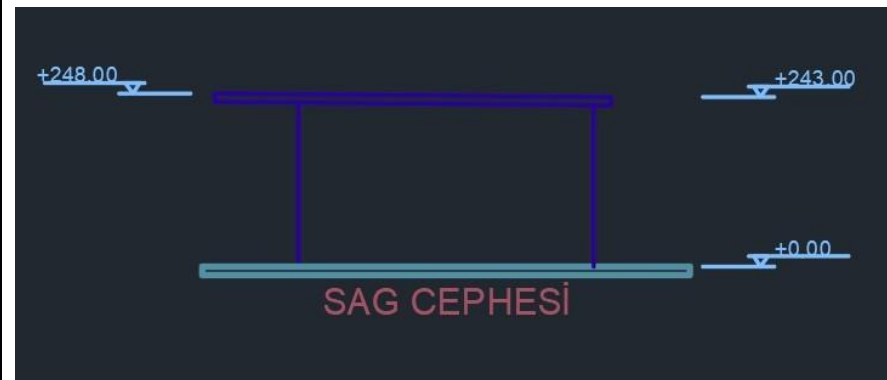
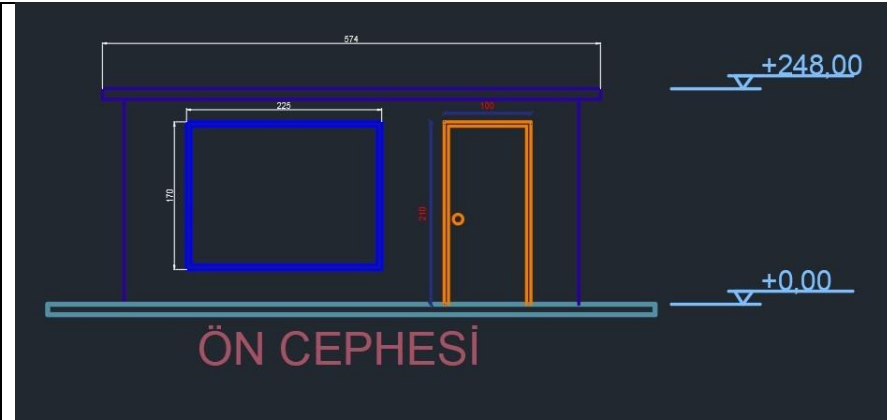

- 25 amp breaker for sockets should be used on the outside and one inside apparent wire to connect an AC.

Surface-mounted connections should be made. Electrical installation should be done on the right side of the door entrance and on the other side of it. The supply cable is a ttr cable with a cross section of 3\*2.5 and therefore there should be a machine etc. that will consume electricity in the shop in accordance with the load that the cable in this cross section will carry. should be used. There should be 1 socket, 1 switch, 1 lamp and button. All electrical materials must comply with TSE standards.

**Door**

Door dimensions: 100 \* 210 cm. The width of the frame is 10 cm and there should be a sill only on the long side and the short side on the outside. Composite / Membrane Door should be used. Exterior door lock must be used, lock, hinge and handle must comply with TSE standards. The door should open to the inside area to the right wall side. Glassless Door. White, Brown, Cream and light gray tones should be used as colors.

**Window/Glass**

6 mm Tempered Flat singleglass should be used. Tempered glass should be used in terms of being more resistant to impact and occupational health and safety. There will be no opening wings on the glass. It should be 170\* 225 cm in size including the case. The glass must comply with the TSE standard.

**Assembly**

Wooden house type Shops should be brought to the area where the assembly will be made as disassembled and assembly should be done at that point. In order for the assembly to be made, it is possible if the ground is flat and the conditions for assembly are made. It can assemble about 8-10 shops per day.



**All materials to be used during production must comply with TSE Standards.**

**Warranty Period**

Natural disasters, External factors, Extra additions to be made after delivery, electricity, etc. There should be at least 1 year warranty period, except for the problems that will occur due to the effect of the product and user error.

**Other Circumstances/ Considerations**

If an electric heater-stove is to be used for heating in the shop, it should be at least 50 cm away from the surface and walls. In the case of installing a normal stove, the exit point of the pipe should be insulated against heat in particular. Otherwise, there is a possibility of fire. Wood must be protected from water and moisture. Otherwise, rotting and damping begin. If water is to be used in the shop, the drains should be connected properly and the floor should not get water.

Cleaning the interior of the shop, the interior surface, walls and floor should be wiped with a damp cloth-mop. It should not be particularly wet.

**Increasing its durability:** Every year, the outer surface is sanded with 220 grit sandpaper and water-based varnish is applied with the help of a brush and/or a gun. It ensures that the structure remains alive, bright and long-lasting.

Before the installation, the employer has completed the subfloor works, isolated it from the soil and must prepare a flat ground.





**Wooden HOUSE type Shop consists of 1 room.****Production Dimensions**

External Dimensions: 4740\*6740 mm

Internal Dimensions: 4000 \* 6000 mm

Interior Space m<sup>2</sup>: 24

It consists of 7 panels in total.

(Base, side right and left panel, front rear panel, two roof panels)

**Technical Data**snow load: 80 kg/m<sup>2</sup>

Wind load: 105 km/hr

All sections are shown in the attached Plan.

**Base**

1-2 class Yellow Pine/Spruce Timber with Oven frame, measuring 6\*9 cm, should be used as floor wedges. On it, 1-2 class San Pine/ Spruce Oven timber frame with 27 mm thickness should be nailed with 25\*70 mm ring nails. The humidity of the material to be used should be below 15%. Total package thickness is 12 cm. The floor should be painted with water-based paint-varnish. The materials to be used on the base must be waterproof And on top of the pine/Spruce wood , plywood plate 18mm thickness with gray color waterproof paint.

**Exterior Walls**

Paneling made of 1-2 class Yellow Pine/Spruce Timber frame should be used. It must be made of wood with oven-timber and the humidity must be below 15%. The width of the panel should be 10 cm, 12 cm and 15 cm. The Main Carcass measures 4\*9 cm and the paneling should be fixed to this carcass. Water-based varnish should be applied on the paneling and waterproofing

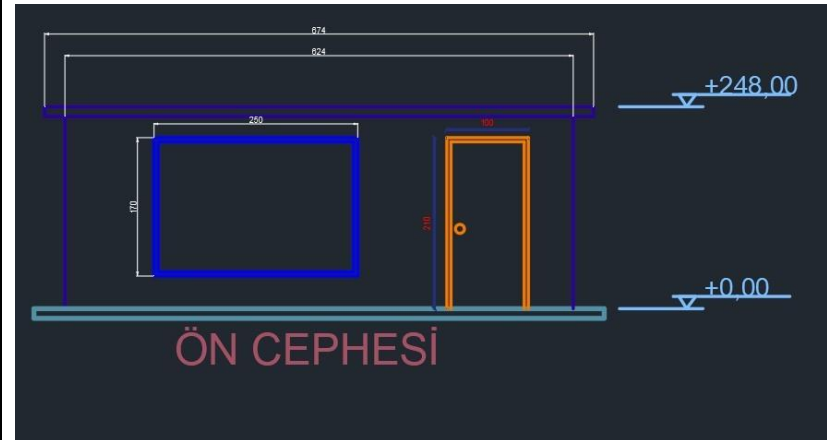
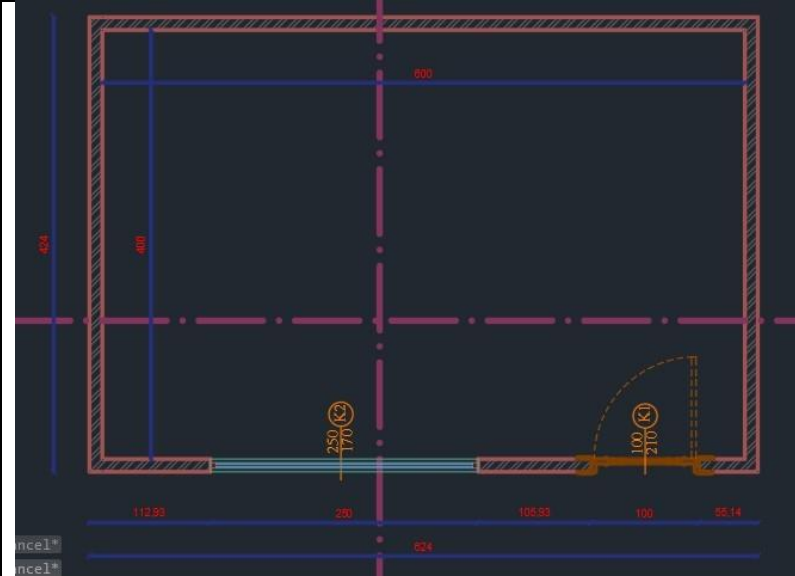

should be provided. A light single color should be used. Paneling should be nailed with 25\*55 mm ring nails.

#### Interior Walls

1-2 class Yellow Pine/Spruce Timber frame should be used in 4\*9 cm Wood Carcass and the humidity rate should be below 15%. Panel width should be 10 cm, 12 cm and 15 cm. 8 mm MDF Lam, in other words painted MDF, should be nailed to the inside of the main carcass. MDF carrier should be nailed to the main frame with 4d headless nails and/or 25\*40 mm screws.

#### Roof

the roof is ergonomically heavy, it consists of 2 (two) equal parts. 4\*9 cm 1-2 class Yellow Pine / Spruce kiln timber frame should be used. Humidity should be below 15%. Paneling made of 18 mm 1-2 class San Pine/ Spruce timber should be nailed to the carcass consisting of 4\*9 cm. Humidity rate should be below 15% as it is oven-panel.

2-3 mm membrane coating should be nailed on the paneling with 2 cm shingle nails. On top of that, Slate Shingle Coating should be nailed with 2 cm shingle nails. Membrane coating and Slate Shingle material must comply with TSE standards. Total thickness should be 12.5 cm. Waterproofing must be ensured. It should be applied between the roof and the outer walls with one's hand on the waist. Adding at high 2,43 m side ( PVC 110 mm k-style Rain Gutter – Brown) with all parts (end cap-brackets -corner joint..etc) .the downspout outlet And all the downspout outlet will connect with downspout section and the connection until ground.

#### Electrical Installation

85mm \*85mm input junction box, one differential breaker 30mA delta, with Ampers capacity adapting to the input. Then two circuits:

- 10 amps breaker for indoor lighting + one inside socket



- 25 amp breaker for sockets should be used on the outside and one inside apparent wire to connect an AC.

Surface-mounted connections should be made. Electrical installation should be done on the right side of the door entrance and on the other side of it. The supply cable is a ttr cable with a cross section of 3\*2.5 and therefore there should be a machine etc. that will consume electricity in the shop in accordance with the load that the cable in this cross section will carry. should be used. There should be 1 socket, 1 switch, 1 lamp and button. All electrical materials must comply with TSE standards.

**Door**

Door dimensions: 100 \* 210 cm. The width of the frame is 10 cm and there should be a sill only on the long side and the short side on the outside. Composite / Membrane Door should be used. Exterior door lock must be used, lock, hinge and handle must comply with TSE standards. The door should open to the inside area to the right wall side. Glassless Door. White, Brown, Cream and light gray tones should be used as colors.

**Window/Glass**

6 mm Tempered Flat singleglass should be used. Tempered glass should be used in terms of being more resistant to impact and occupational health and safety. There will be no opening wings on the glass. It should be 170\*250 cm in size including the case. The glass must comply with the TSE standard.

**Assembly**

Wooden house type Shops should be brought to the area where the assembly will be made as disassembled and assembly should be done at that point. In order for the assembly to be made, it is possible if the ground is flat



and the conditions for assembly are made. It can assemble about 8-10 shops per day.

**All materials to be used during production must comply with TSE Standards.**

**Warranty Period**

Natural disasters, External factors, Extra additions to be made after delivery, electricity, etc. There should be at least 1 year warranty period, except for the problems that will occur due to the effect of the product and user error.

**Other Circumstances/ Considerations**

If an electric heater-stove is to be used for heating in the shop, it should be at least 50 cm away from the surface and walls. In the case of installing a normal stove, the exit point of the pipe should be insulated against heat in particular. Otherwise, there is a possibility of fire. Wood must be protected from water and moisture. Otherwise, rotting and damping begin. If water is to be used in the shop, the drains should be connected properly and the floor should not get water.

Cleaning the interior of the shop, the interior surface, walls and floor should be wiped with a damp cloth-mop. It should not be particularly wet.

**Increasing its durability:** Every year, the outer surface is sanded with 220 grit sandpaper and water-based varnish is applied with the help of a brush and/or a gun. It ensures that the structure remains alive, bright and long-lasting.

Before the installation, the employer has completed the subfloor works, isolated it from the soil and must prepare a flat ground.



**Wooden HOUSE type Shop consists of 1 room.**

#### Production Dimensions

External Dimensions: 4740\*8740 mm

Internal Dimensions: 4000 \* 8000 mm

Interior Space m<sup>2</sup>: 32

It consists of 7 panels in total.

(Base, side right and left panel, front rear panel, two roof panels)

#### Technical Data

snow load: 80 kg/m<sup>2</sup>

Wind load: 105 km/hr

All sections are shown in the attached Plan.

#### Base

1-2 class Yellow Pine/Spruce Timber with Oven frame, measuring 6\*9 cm, should be used as floor wedges. On it, 1-2 class San Pine/ Spruce Oven timber frame with 27 mm thickness should be nailed with 25\*70 mm ring nails. The humidity of the material to be used should be below 15%. Total package thickness is 12 cm. The floor should be painted with water-based paint-varnish. The materials to be used on the base must be waterproof And on top of the pine/Spruce wood , plywood plate 18mm thickness with gray color waterproof paint.

#### Exterior Walls

Paneling made of 1-2 class Yellow Pine/Spruce Timber frame should be used. It must be made of wood with oven-timber and the humidity must be below 15%. The width of the panel should be 10 cm, 12 cm and 15 cm. The Main Carcass measures 4\*9 cm and the paneling should be fixed to this carcass. Water-based varnish should be applied on the paneling and waterproofing

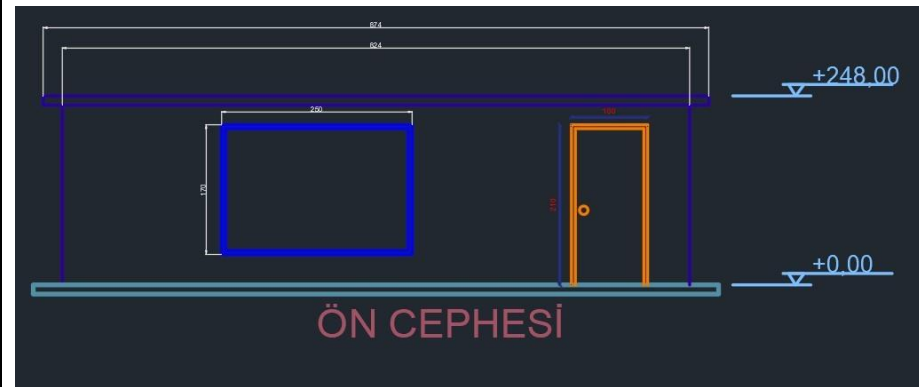
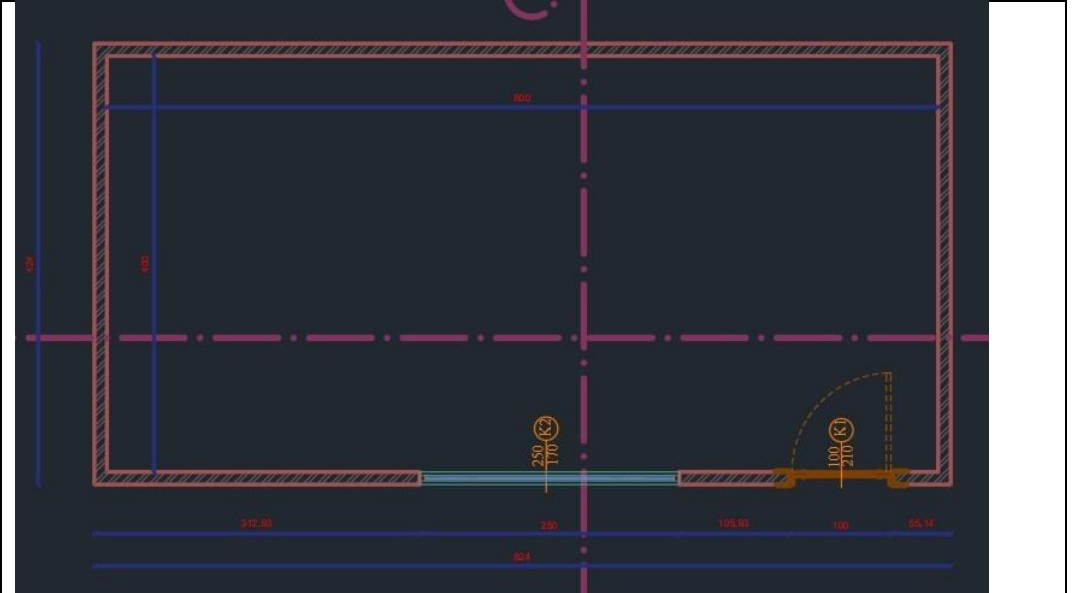

should be provided. A light single color should be used. Paneling should be nailed with 25\*55 mm ring nails.

#### Interior Walls

1-2 class Yellow Pine/Spruce Timber frame should be used in 4\*9 cm Wood Carcass and the humidity rate should be below 15%. Panel width should be 10 cm, 12 cm and 15 cm. 8 mm MDF Lam, in other words painted MDF, should be nailed to the inside of the main carcass. MDF carrier should be nailed to the main frame with 4d headless nails and/or 25\*40 mm screws.

#### Roof

the roof is ergonomically heavy, it consists of 2 (two) equal parts. 4\*9 cm 1-2 class Yellow Pine / Spruce kiln timber frame should be used. Humidity should be below 15%. Paneling made of 18 mm 1-2 class San Pine/ Spruce timber should be nailed to the carcass consisting of 4\*9 cm. Humidity rate should be below 15% as it is oven-panel.

2-3 mm membrane coating should be nailed on the paneling with 2 cm shingle nails. On top of that, Slate Shingle Coating should be nailed with 2 cm shingle nails. Membrane coating and Slate Shingle material must comply with TSE standards. Total thickness should be 12.5 cm. Waterproofing must be ensured. It should be applied between the roof and the outer walls with one's hand on the waist. Adding at high 2,43 m side ( PVC 110 mm k-style Rain Gutter – Brown) with all parts (end cap-brackets -corner joint..etc) .the downspout outlet And all the downspout outlet will connect with downspout section and the connection until ground.

#### Electrical Installation

85mm \*85mm input junction box, one differential breaker 30mA delta, with Ampers capacity adapting to the input. Then two circuits:

- 10 amps breaker for indoor lighting + one inside socket
- 25 amp breaker for sockets should be used on the outside and one inside apparent wire to connect an AC.

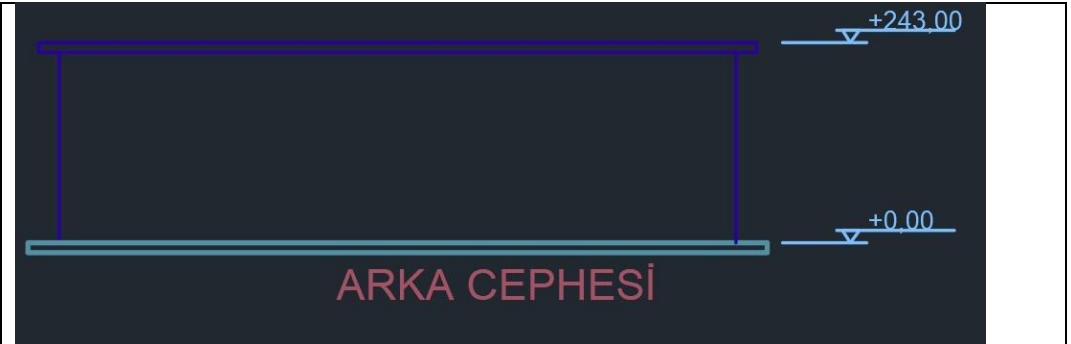

Surface-mounted connections should be made. Electrical installation should be done on the right side of the door entrance and on the other side of it. The supply cable is a ttr cable with a cross section of 3\*2.5 and therefore there should be a machine etc. that will consume electricity in the shop in accordance with the load that the cable in this cross section will carry. should be used. There should be 1 socket, 1 switch, 1 lamp and button. All electrical materials must comply with TSE standards.

**Door**

Door dimensions: 100 \* 210 cm. The width of the frame is 10 cm and there should be a sill only on the long side and the short side on the outside. Composite / Membrane Door should be used. Exterior door lock must be used, lock, hinge and handle must comply with TSE standards. The door should open to the inside area to the right wall side. Glassless Door. White, Brown, Cream and light gray tones should be used as colors.

**Window/Glass**

6 mm Tempered Flat single glass should be used. Tempered glass should be used in terms of being more resistant to impact and occupational health and safety. There will be no opening wings on the glass. It should be 170\*250 cm in size including the case. The glass must comply with the TSE standard.

**Assembly**

Wooden house type Shops should be brought to the area where the assembly will be made as disassembled and assembly should be done at that point. In order for the assembly to be made, it is possible if the ground is flat and the conditions for assembly are made. It can assemble about 8-10 shops per day.

**All materials to be used during production must comply with TSE Standards.**



**Warranty Period**

Natural disasters, External factors, Extra additions to be made after delivery, electricity, etc. There should be at least 1 year warranty period, except for the problems that will occur due to the effect of the product and user error.

**Other Circumstances/ Considerations**

If an electric heater-stove is to be used for heating in the shop, it should be at least 50 cm away from the surface and walls. In the case of installing a normal stove, the exit point of the pipe should be insulated against heat in particular. Otherwise, there is a possibility of fire. Wood must be protected from water and moisture. Otherwise, rotting and damping begin. If water is to be used in the shop, the drains should be connected properly and the floor should not get water.

Cleaning the interior of the shop, the interior surface, walls and floor should be wiped with a damp cloth-mop. It should not be particularly wet.

**Increasing its durability:** Every year, the outer surface is sanded with 220 grit sandpaper and water-based varnish is applied with the help of a brush and/or a gun. It ensures that the structure remains alive, bright and long-lasting.

Before the installation, the employer has completed the subfloor works, isolated it from the soil and must prepare a flat ground.

